

RIGHT ANGLE PCB RECEPTACLE

R113.665.137

SOLDER LEGS

Series : MCX

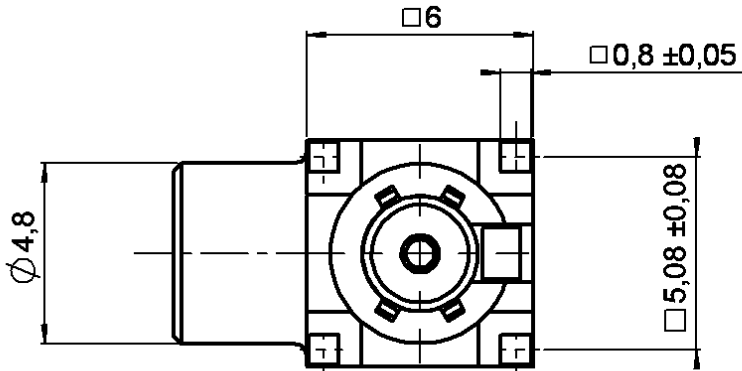

PANEL CUT OUT

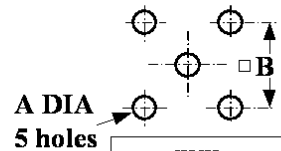

mm		
	Maxi	mini
A	1.4	1.3
B	5.13	5.03

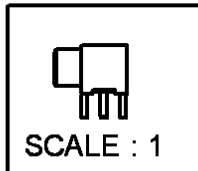
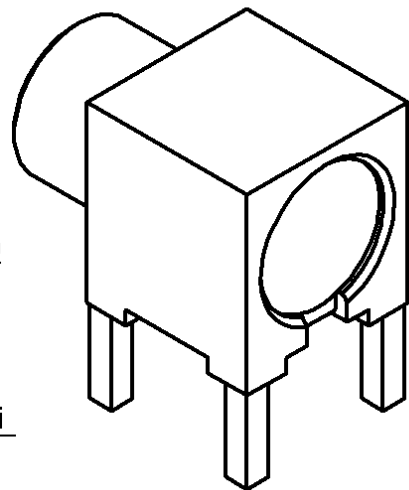
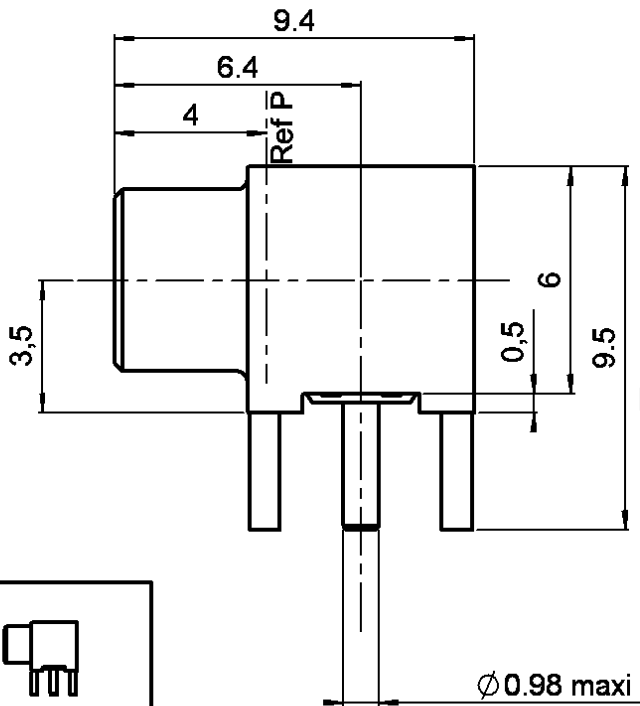

All dimensions are in mm.



COMPONENTS	MATERIALS	PLATINGS (µm)
BODY	BRASS	GBR 2
CENTER CONTACT	BERYLLIUM COPPER	GOLD 1.3 OVER NICKEL 2
OUTER CONTACT	-	-
INSULATOR	PTFE	-
GASKET	-	-
OTHERS PARTS	BRASS	BBR .
.	.	.
.	.	.

Issue : 0116 D

In the effort to improve our products, we reserve the right to make changes judged to be necessary.



RIGHT ANGLE PCB RECEPTACLE

R113.665.137

SOLDER LEGS

Series : MCX

PACKAGING

SPECIFICATION

Standard	Unit	Other
100	'W' option	Contact us

1301-RNT 403 130 / 5 Rev. L A 00

ELECTRICAL CHARACTERISTICS

ENVIRONMENTAL

Impedance		50 Ω
Frequency		0-6 GHz
VSWR	1.05 +	0.015 x F(GHz) Maxi
Insertion loss		0.03 √F(GHz) dB Maxi
RF leakage	- (NA - F(GHz)) dB Maxi
Voltage rating		335 Veff Maxi
Dielectric withstanding voltage		1000 Veff mini
Insulation resistance		1000 MΩ mini

Operating temperature	-55/+155 ° C
Hermetic seal	NA Atm.cm3/s
Panel leakage	NA

OTHERS CHARACTERISTICS

Assembly instruction

Others :

MECHANICAL CHARACTERISTICS

Center contact retention		
Axial force – Mating end	10	N mini
Axial force – Opposite end	10	N mini
Torque	NA	N.cm mini
Recommended torque		
Mating	NA	N.cm
Panel nut	NA	N.cm
Mating life	500	Cycles mini
Weight	0.000	g

Issue : 0116 D

In the effort to improve our products, we reserve the right to make changes judged to be necessary.

